

BALTOSCOPE FPDigit 16-139

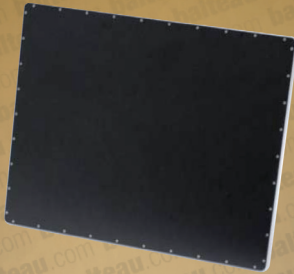

Receptor type:	Amorphous silicon
Conversion screen:	DD CSI, DRZplus
Pixel area:	24,9 x 30,2
Pixel pitch:	139 µm²
Spatial resolution:	3,60 lp/mm
Energy Range:	40-160 kVp
AD/conversion:	16 bits
Frame rate:	Up to 32
Standard shielding:	160 kV
Power supply:	100-240 VAC
System interface:	Gigabit Ethernet
Weight:	4,1 kg

Improved reliability in inspections, costs reductions and environment cares are today the major factors driving the selection of Radiographic techniques. Due to the progression of silicon technologies and the level of current electronics, signals processing and transfer are becoming efficient and affordably priced to be used in NDT Industries.

Flat panels are a combination of electronic and Silicon technologies which gives a direct conversion media for displaying Radiographic Images instead of using films. Flat panels are basically a two dimension array of detectors which sensitivity is 10 to 100 times greater than conventional films. This helps in reducing exposure time but also gives an extended range of thicknesses with the same use of energy.

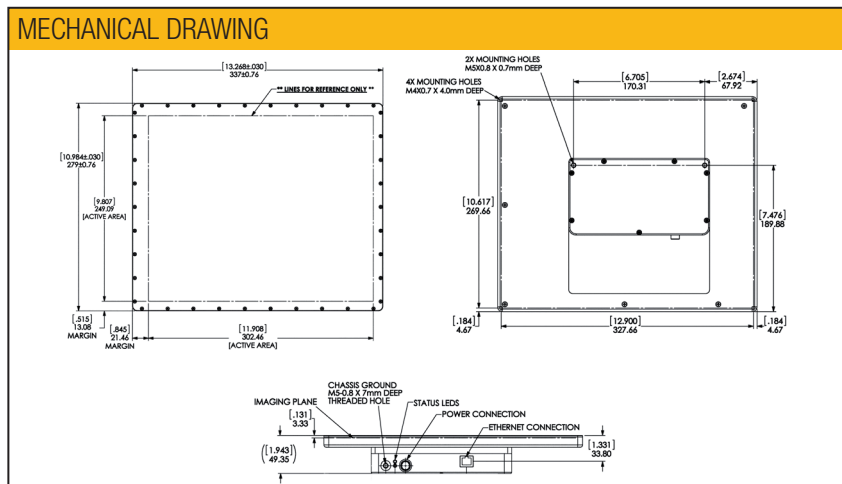

Flexibility

Compared to classical Film radiography, the FPDigit provides: the choice in beam or view incidence to give the selected view of an indication in the product, enlargement capabilities and inspection cost reductions. This is giving a fast decision (compared to film) thanks to direct observation in the screen of the monitor of the FPDigit control unit.

The resolution

The resolution of a flat panel is a function of several factors. The pitch size will give the spatial resolution of the detector and must be selected taking into account Applications, X ray sources and Budgets. The smaller the pixel is, the higher resolution can be. But the same result can sometimes be obtained using Magnification if Geometry of exposure and X ray sources are correctly selected. The pitch size directly interferes on the Modulation Transfer Frequency (MTF) or the Spatial Frequency Response. The MTF defines the sharpness of a whole system for displaying fine details. This is then the final result in terms of definition for the said detector. MTF are expressed in pairs of lines. The driving electronic attached to the panel is another very important factor as it will collect and send the signal to the

computer with more or less efficiency depending on the construction and quality. For instance, Shielding (intrinsically) of this section to the appropriate level of energy will guarantee that no noise or even worse, no damages, will happen to the module.

«Real» Real time

Fast conversion system where no latency is expected due to the working mode. Acquisition rates are as fast as a human eye can see and there are basically no integration time. However, if required, the user may freely select the integration parameters and get slower frame rates but increased X ray sensitivity.

Image enhancement

If you display a given size indication on a defined area and you increase the size of the displaying area, you will get an increased definition or precision when measuring the indication. That will help him emphasizing tiny details that are barely visible otherwise. This greatly helps interpretation works too and provides an excellent tool for Real time process monitoring.

Specifications	Units	BALTOSCOPE FPDigit 16-139
Dimensions:	mm	337 (w) x 279 (l) x 49,35 (h)
Weight:	kg	4,1
Housing:		Aluminium
Receptor Type:		Amorphous silicon
Conversion screen:		Direct Deposit CSI, DRZplus
Pixel matrix - Total:		1792 x 2176 (1 x 1)
Pixel pitch:	μm^2	139
Spatial resolution:	lp/mm	3,60
A/D Conversion	bits	16
Energy range (standard):	kVp	40 - 160
Scan method:		Progressive
MTF		> 48% @ 1 lp/mm (1x1), CSI screen
Fill factor		57 %
Standard shielding:		Shielded for 160 kV X-ray radiation
System Interface:		Gigabit Ethernet
Power supply:		100 - 240 VAC / 47 - 63 Hz
Power Dissipation:	V	15 (typical)
Operating temperature:	$^{\circ}\text{C}$	10 to 35
Storing temperature:	$^{\circ}\text{C}$	-20 to 70
Humidity (Operating/storage):	%	10 to 90

OPTIONAL EQUIPMENT: Acquisition software module, IPS012 Image Processing Software, IPS Report, RIO, ADR, etc.

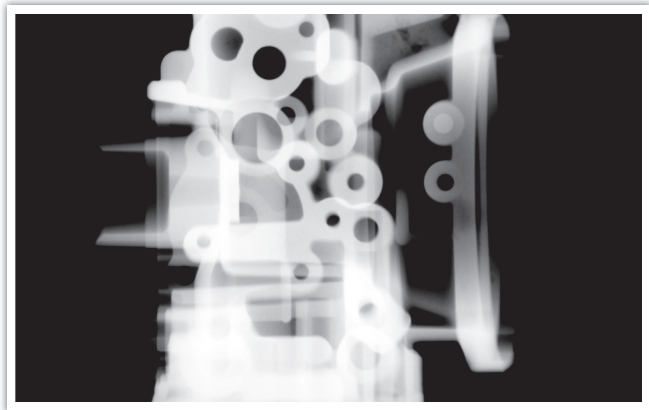
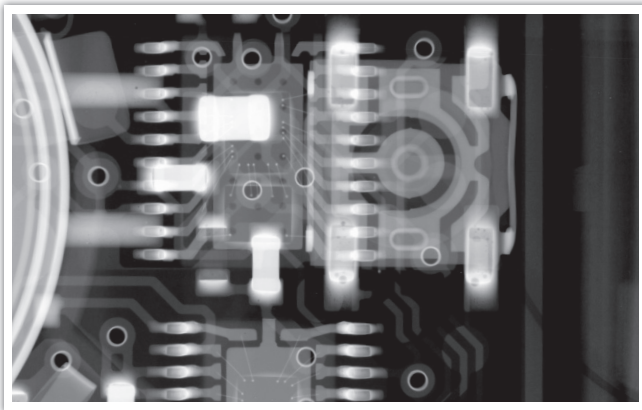

Contact details

Balteu NDT

Rue Voie de Liège, 12
B-4681 Hermalle Sous Argenteau
Belgium

www.balteu.com

balteu@balteu.com

Tel. +32 (0) 4 374 75 75

Fax +32 (0) 4 374 75 85

Distributed by:

